



Installation Data Sheet
 Series: 1:1 Belt Drive SM.3
 Document No.: TI-DATA-2018-SM 7.5T 10T 15T
 Version: 2.1
 Revision Date: 12/8/25

Model	SM 7.5T			SM 10T			SM 15T					
	125	160	217	125	160	217	125	160	217			
I. COOLING DATA												
Cooling System Available [Std., Opt.]	A/C			A/C			A/C					
Standard Ambient Temp. Range [°F]	40 - 115			40 - 115			40 - 115					
VENTILATION OF COMPRESSOR ROOM												
Air Inlet Opening [sq. ft. free area] (A/C) Z	2.7			3.2			3.8					
Solution A (forced ventilation with exhaust fan) as shown in service manual												
Cooling Fan Capacity [CFM] (A/C)	1,883			2,178			2,590					
Solution B (exhaust air used for space heating) as shown in service manual												
Internal Cooling Fan Capacity [CFM] (A/C)	Compressor	Dryer		Compressor	Dryer		Compressor	Dryer				
	1,295	412		1,295	412		1,295	412				
Max. Additional Pressure Drop for Ducts [inch Water Column] (A/C)	0.12			0.12			0.08					
Exhaust Air Opening Reference Dimensions (L x W) [in]	26 x 26			26 x 26			26 x 26					
<p>See drawing for actual dimensions. The actual individual duct dimension will vary for every installation based on actual length, number and type of bends, accessories etc.</p>												
<p>Model shown for reference only Actual Duct size may vary with installation</p>												
Solution A Exhaust Fan												
Solution B Exhaust Duct												
Ventilation of Compressor Room Z												
AIR COOLED DATA												
Internal Cooling Fan Capacity [CFM]	1,295			1,295			1,295					
Approach Temp. [°F]	Reference conditions: 14.5 psia, 30% relative humidity and 68°F inlet air temperature.			9	7.2	7.2	12.6	10.8	9	14.4	12.6	10.8
Typical Heat Rejected [BTU / HR]	26,000			33,500			41,000					



Installation Data Sheet
Series: 1:1 Belt Drive SM.3
Document No.: TI-DATA-2018-SM 7.5T 10T 15T
Version: 2.1
Revision Date: 12/8/25

Model	SM 7.5T			SM 10T			SM 15T					
	125	160	217	125	160	217	125	160	217			
Rated Pressure [psig]												
II. ELECTRICAL DATA <i>Electrical data may vary in accordance with motor manufacturer's specifications. Motors are EISA compliant.</i>												
DRIVE MOTOR												
Motor HP	7.5			10			15					
Insulation Class	F			F			F					
Standard Voltage	208-230/460V/3ph/60Hz			208-230/460V/3ph/60Hz			208-230/460V/3ph/60Hz					
Full Load Amps [FLA] @ 208V/3ph/60Hz	19			26			37.4					
Full Load Amps [FLA] @ 230V/3ph/60Hz	18.1			25			35.5					
Full Load Amps [FLA] @ 460V/3ph/60Hz	9.2			12.4			17.8					
Full Load Amps [FLA] @ 575V/3ph/60Hz	7			10			14					
TOTAL PACKAGE DATA (A/C)												
Do NOT operate package on an unsymmetrical power supply. Also do NOT operate package power supplies such as a three-phase WYE system with the center point not solidly grounded or on a three-phase (open) delta system. The machine requires a symmetrical three-phase power supply transformer with a WYE configuration as shown. With a symmetrical three-phase supply the phase angles and voltages are all the same. Other power supplies are not suitable.						Three-phase star circuit (WYE); 3 wire; center point solidly grounded						
Continuous Duty [Hours per day]	24			24			24					
Control Cabinet Class (NEMA)	12			12			12					
Short Circuit Current Rating (SCCR) [kA] @ 208V 230V 460V/3ph/60Hz	Field installed fuse required, see below*			50			50					
Short Circuit Current Rating (SCCR) [kA] @ 575V/3ph/60Hz	Field installed fuse required, see below*			50			50					
Package Full Load Amps @ 208V/3ph/60Hz [FLA]	28			36			42					
Package Full Load Amps @ 230V/3ph/60Hz [FLA]	26			34			40					
Package Full Load Amps @ 460V/3ph/60Hz [FLA]	13			17			20					
Package Full Load Amps @ 575V/3ph/60Hz [FLA]	11			13			16					
Recommended Disconnect Fuse Size [Amps] @ 208V/3ph/60Hz	*Time delay (dual element) fuse; Class J ≤ 600A (e.g. AJT) / Class L > 600A (e.g. A4BQ). Based on 2020 NEC 240.6, 430.52, and Tables 430.52, 430.248, and 430.250			40			50			60		
Recommended Disconnect Fuse Size [Amps] @ 230V/3ph/60Hz				40			50			60		
Recommended Disconnect Fuse Size [Amps] @ 460V/3ph/60Hz				20			25			30		
Recommended Disconnect Fuse Size [Amps] @ 575V/3ph/60Hz				15			20			25		
Recommended Disconnect Wire Size [AWG/kcmil] @ 208V/3ph/60Hz	The following multi-strand copper core wires are given according to 2020 NEC 310.14, 310.15, 310.16 and table 310.16 adjusted for 40°C ambient temperature. If other local conditions prevail, for example high temperature, the cross section should be checked and adjusted according to 2020 NEC 110.14(C), 220.3, 310.14, 310.15, 310.16, 430.6, 430.22, 430.24, 670.4(A) and other local codes.			8 AWG per phase and ground			6 AWG per phase and ground			6 AWG per phase and ground		
Recommended Disconnect Wire Size [AWG/kcmil] @ 230V/3ph/60Hz				8 AWG per phase and ground			8 AWG per phase and ground			6 AWG per phase and ground		
Recommended Disconnect Wire Size [AWG/kcmil] @ 460V/3ph/60Hz				14 AWG per phase and ground			10 AWG per phase and ground			10 AWG per phase and ground		
Recommended Disconnect Wire Size [AWG/kcmil] @ 575V/3ph/60Hz				14 AWG per phase and ground			14 AWG per phase and ground			12 AWG per phase and ground		



Installation Data Sheet
Series: 1:1 Belt Drive SM.3
Document No.: TI-DATA-2018-SM 7.5T 10T 15T
Version: 2.1
Revision Date: 12/8/25

Model	SM 7.5T			SM 10T			SM 15T			
	Rated Pressure [psig]	125	160	217	125	160	217	125	160	217
INSTALLATION and MAINTENANCE DATA										
A/C with Super Soundproofing [dB(A)]	SOUND PRESSURE LEVEL [Measured in dB(A) according to ISO 2151 using ISO 9614-2]			65	67			68		
A/C Air Discharge [inches NPT or Flange]	3/4 NPT			3/4 NPT			3/4 NPT			
Power Input Conduit Opening(s) [inches]	1 5/8			1 5/8			1 5/8			
Condensate Drain Connection [NPT]	1/4			1/4			1/4			
Width [inches]	24 3/4			24 3/4			24 3/4			
Depth [inches]	43			43			43			
Height [inches]	43 1/4			43 1/4			43 1/4			
Floor Space [sq. ft.]	7 3/8			7 3/8			7 3/8			
Weight [lb]	Weight may vary based on a/rend selected.			650	695			695		
COMPRESSOR FLUID DATA										
Fluid Capacity (A/C) [gal]	1.1			1.1			1.1			
Flow Rate [gal/min]	2.4			2.4			2.4			
Typical Oil Consumption [fl. Oz./100 h]	0.81			1.1			1.4			
Standard Fluid Type	Sigma S-460			Sigma S-460			Sigma S-460			
MAINTENANCE PARTS										
Air Inlet Filter				6.5212.0						
Filter Mat (optional)				5.3353.0						
Filter Mat for Control Cabinet				6.3572.0 (x4)						
Fluid Filter				6.3462.1						
Fluid Separator Kit				6.3795.1						
Maintenance Kit for Optional 5-year warranty				ANAKSM3S						
Maintenance Kit for Optional 5-year warranty, with food-grade lubricant				ANAKSM3F						
DRYER DATA - FOR T MODELS										
Dryer Model	ABT15			ABT15			ABT15			
Maximum Inlet Air Pressure (Compressed Air at Inlet to Dryer) [psig]	232			232			232			
Nominal Pressure Drop at Rated Flow [psid]	2.9			2.9			2.9			
Rated Dewpoint [°F] at Standard Conditions	Reference conditions: 14.5 psia, 30% relative humidity and 68°F inlet air temperature.			38	38			38		
REFRIGERATION SYSTEM DATA - FOR T MODELS										
Compressor Type	AE4430Y-GS			AE4430Y-GS			AE4430Y-GS			
BTU/Refrigeration ASHRAE	2832			2832			2832			
Outlet Air Temperature (Nominal at Rated Conditions) [°F]	Reference conditions: 14.5 psia, 30% relative humidity and 68°F inlet air temperature.			74	74			74		
Refrigerant Type	R-513A			R-513A			R-513A			
GWP (Global Warming Potential)	629			629			629			
CO2 equivalent [t]	0.25			0.25			0.25			
Refrigerant Charge [lb]	0.86			0.86			0.86			
Air Flow Across Condenser [CFM]	412			412			412			
Air Receiver Tank Size - AIRCENTER units only [gal]	Simplex/Duplex tank size 100 gallons			71.3	71.3			71.3		

Model	SM 7.5T			SM 10T			SM 15T		
	125	160	217	125	160	217	125	160	217
Rated Pressure [psig]									

SAMPLE SKETCHES

Sample Installation Planning
Examples of room ventilation and ductwork
 Please note the upsizing required for compressor exhaust ducts

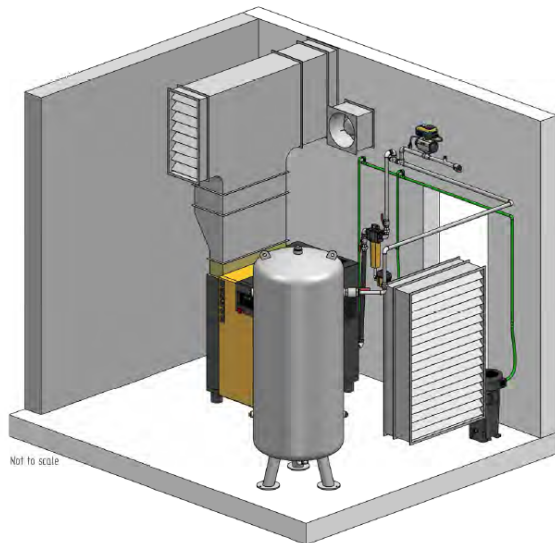

SK 20 T / F26KE Sample Layout

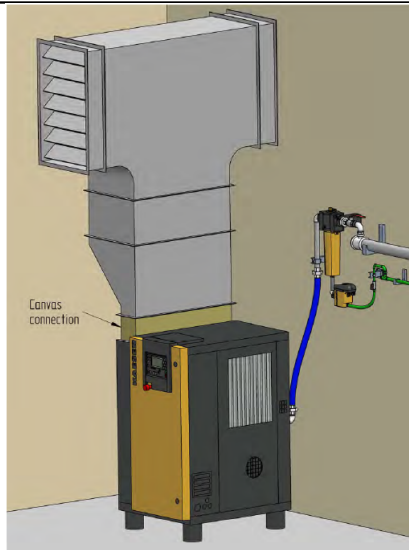

Duct / Pipe connection SM

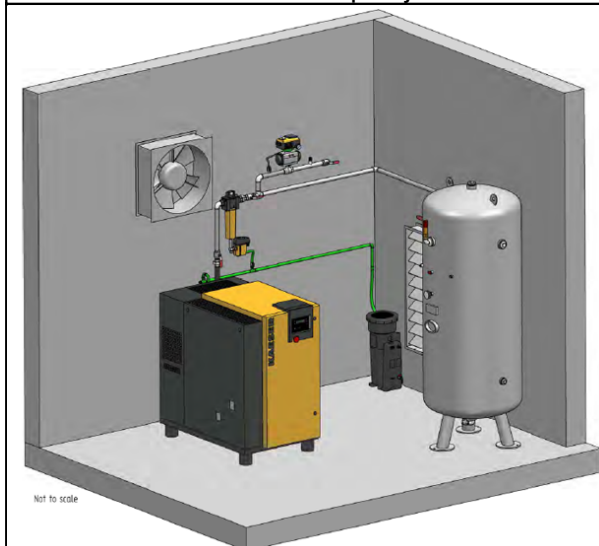
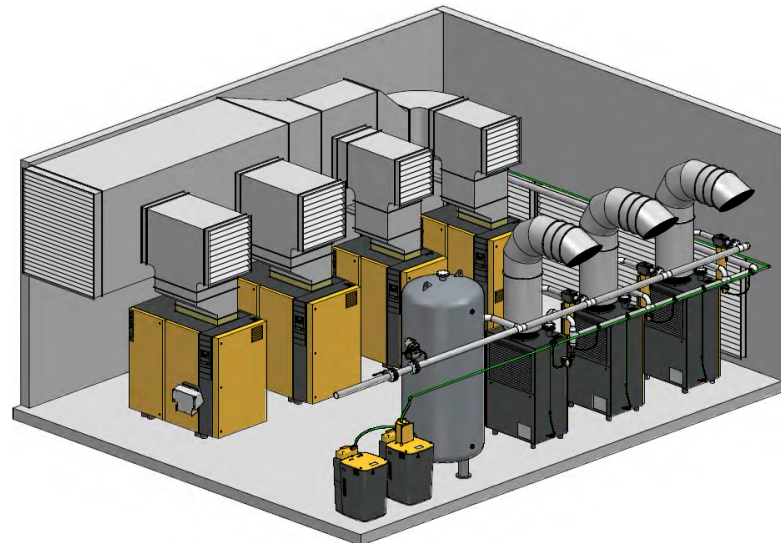

SK 20 T / F26KE Sample Layout

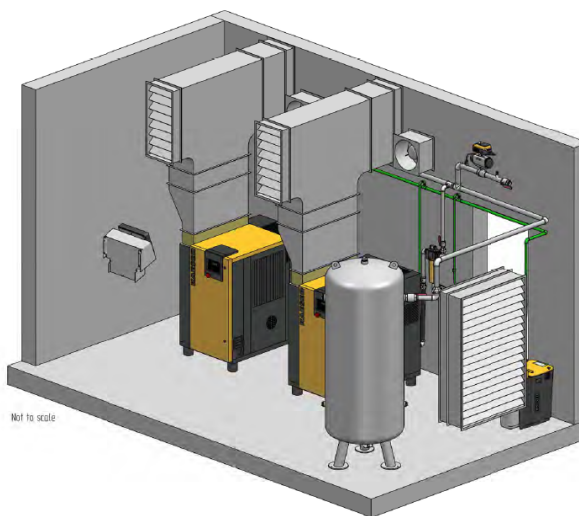

(2x) SK 20 T / (2x) F26KE

Example designs only, not for construction purposes.