

Installation Data Sheet - i.Comp

Series: i.Comp 9

Document Number: TI-DATA-2022-i.COMP9

Version: 1.0

Revision Date: 10/21/2022

Package Model	i.Comp 9
----------------------	----------

Electrical Data			
Machine configuration	G	Tower	Tower T
Horsepower	5.6	5.6	5.6
Voltage (3ph/60Hz)	460V	460V	460V
Short Circuit Current Rating (SCCR) [kA] 460V/3ph/60Hz	50	50	50
Package FLA +/- 10%	6.3	6.3	6.3
Disconnect Fuse [Amp]	20	20	20
Compressor Recommended Wire Size (75°C or higher) [AWG]	12	12	12
Dryer voltage (1ph/60Hz)	N/A	N/A	115V
Dryer Disconnect Fuse [Amp]	N/A	N/A	15
Dryer Recommended Wire Size (75°C or higher) [AWG]	N/A	N/A	14
Dryer FLA +/- 10%	N/A	N/A	4.6

Notes:

1. Time delay (dual element) fuse; Class J ≤ 600A (e.g. AJT).
2. Fuse and wire sizes determined in accordance to NEC 240.6, 430.52 and tables 250.122, 430.248, 430.250.
3. Breaker should be suitable for a heavy duty starting load and of inverse time delay design that complies to regulations outlines in NEC 430.52.
4. All i.Comp 9 units include SFC. SFC Units come standard at 460 volts.
5. Ground wire size should be equal to conductor size.

Package Connections			
Machine configuration	G	Tower	Tower T
Width (in.)	31	33	33
Depth (in.)	47 3/5	48 2/5	48 2/5
Height (in.)	40 1/2	54 1/3	54 1/3
Floor (sq. ft.)	10	11	11
Weight (lb.)	381	514	573
Connection Size (in.)	1/2" NPT	1/2" NPT	1/2" NPT

General Information			
Ambient Conditions (°F)	40-104		
Max air discharge temperature at max ambient temperature	134	115	107.6
Maximum elevation AMSL (ft)	3000		
Sound emission (dB(A))	65.5		
Number of cylinders	2	2	2
Air receiver volume (gal)	N/A	2 x 10.5	2 x 10.5

Refrigerated Dryer/System Information			
Refrigerant	N/A	N/A	R-513A
Global warming potential (GWP)	N/A	N/A	631
Charge quantity (lb)	N/A	N/A	0.44
Cooling air volume (cfm)	N/A	N/A	447
Pressure drop (psi) [relating to 100 psi working pressure]	N/A	N/A	2.6
Maximum permitted working pressure (psi)	N/A	N/A	232

Ventilation of Blower Room	
Ventilation Air Inlet Opening Z	4.3 sq. ft
Cooling Fan Capacity (forced ventilation) A (ΔT=18°F)	706 CFM

Model shown for reference only

Actual duct size may vary with installation

- A Exhaust Fan
- Z Ventilation Inlet Air Opening

Recommended machine placement and dimensions:

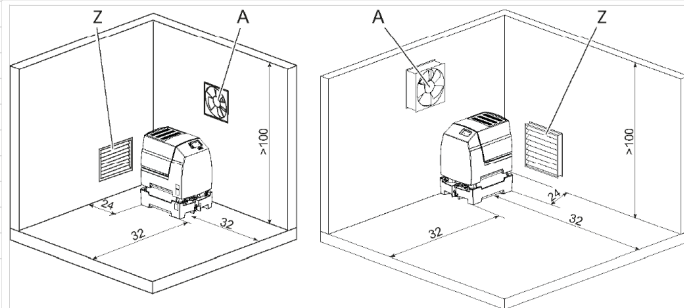

05-P000053-004

*The foundation must be firm and capable of bearing the weight of the machine.